

BRITISH STANDARD

BS EN
124:1994

*Incorporating
Amendment No. 1*

Gully tops and manhole tops for vehicular and pedestrian areas — Design requirements, type testing, marking, quality control

The European Standard EN 124:1994 has the status of a
British Standard

UDC 628.253.1:001.4:620.1

NO COPYING WITHOUT BSI PERMISSION EXCEPT AS PERMITTED BY COPYRIGHT LAW



Cooperating organizations

The European Committee for Standardization (CEN), under whose supervision this European Standard was prepared, comprises the national standards organizations of the following countries:

| | |
|----------------|--|
| Austria | Oesterreichisches Normungsinstitut |
| Belgium | Institut belge de normalisation |
| Denmark | Dansk Standard |
| Finland | Suomen Standardisoimisliito, r.y. |
| France | Association française de normalisation |
| Germany | Deutsches Institut für Normung e.V. |
| Greece | Hellenic Organization for Standardization |
| Iceland | Technological Institute of Iceland |
| Ireland | National Standards Authority of Ireland |
| Italy | Ente Nazionale Italiano di Unificazione |
| Luxembourg | Inspection du Travail et des Mines |
| Netherlands | Nederlands Normalisatie-instituut |
| Norway | Norges Standardiseringsforbund |
| Portugal | Instituto Português da Qualidade |
| Spain | Asociación Española de Normalización y Certificación |
| Sweden | Standardiseringskommissionen i Sverige |
| Switzerland | Association suisse de normalisation |
| United Kingdom | British Standards Institution |

This British Standard, having been prepared under the direction of Technical Committee B/505, Waste Water Engineering, was published under the authority of the Standards Board and comes into effect on 15 October 1994

© BSI 11-1998

The following BSI references relate to the work on this standard:
Committee reference B/505/4
Draft for comment 92/14687 DC

ISBN 0 580 22754 5

Amendments issued since publication

| Amd. No. | Date | Comments |
|----------|----------|---------------------------------------|
| 8587 | May 1995 | Indicated by a sideline in the margin |
| | | |
| | | |
| | | |

BSI — British Standards Institution

BSI is the independent national body responsible for preparing British Standards. It presents the UK view on standards in Europe and at the international level. It is incorporated by Royal Charter.

Revisions

British Standards are updated by amendment or revision. Users of British Standards should make sure that they possess the latest amendments or editions.

It is the constant aim of BSI to improve the quality of our products and services. We would be grateful if anyone finding an inaccuracy or ambiguity while using this British Standard would inform the Secretary of the technical committee responsible, the identity of which can be found on the inside front cover. Tel: 020 8996 9000. Fax: 020 8996 7400.

BSI offers members an individual updating service called PLUS which ensures that subscribers automatically receive the latest editions of standards.

Buying standards

Orders for all BSI, international and foreign standards publications should be addressed to Customer Services. Tel: 020 8996 9001. Fax: 020 8996 7001.

In response to orders for international standards, it is BSI policy to supply the BSI implementation of those that have been published as British Standards, unless otherwise requested.

Information on standards

BSI provides a wide range of information on national, European and international standards through its Library and its Technical Help to Exporters Service. Various BSI electronic information services are also available which give details on all its products and services. Contact the Information Centre. Tel: 020 8996 7111. Fax: 020 8996 7048.

Subscribing members of BSI are kept up to date with standards developments and receive substantial discounts on the purchase price of standards. For details of these and other benefits contact Membership Administration. Tel: 020 8996 7002. Fax: 020 8996 7001.

Copyright

Copyright subsists in all BSI publications. BSI also holds the copyright, in the UK, of the publications of the international standardization bodies. Except as permitted under the Copyright, Designs and Patents Act 1988 no extract may be reproduced, stored in a retrieval system or transmitted in any form or by any means – electronic, photocopying, recording or otherwise – without prior written permission from BSI.

This does not preclude the free use, in the course of implementing the standard, of necessary details such as symbols, and size, type or grade designations. If these details are to be used for any other purpose than implementation then the prior written permission of BSI must be obtained.

If permission is granted, the terms may include royalty payments or a licensing agreement. Details and advice can be obtained from the Copyright Manager. Tel: 020 8996 7070.

National annex NA (informative)

Committees responsible

The United Kingdom participation in the preparation of this European Standard was entrusted by the Technical Committee B/505, Waste Water Engineering, to Subcommittee B/505/4, Manhole Covers, Surface Boxes and other Road Fittings, upon which the following bodies were represented:

Association of London Borough Engineers and Surveyors
British Foundry Association
British Plastics Federation
British Precast Concrete Federation Ltd.
Clay Pipe Development Association Limited
County Surveyor's Society
Department of the Environment
Department of Transport
Ductile Iron Pipe Committee
Galvanizers' Association
Institute of British Foundrymen
Institute of Building Control
Institution of Water and Environmental Management
Institution of Works and Highways Management
METCOM
National Clayware Federation
Society of British Water Industries
Water Companies Association
Water Services Association of England and Wales
Co-opted members

National annex NB (informative)

Cross-references

| Publication referred to | Corresponding British Standard |
|-----------------------------|--|
| EN 29002:1987 ¹⁾ | BS 5750 <i>Quality systems</i> Part 2:1987 <i>Specification for production and installation</i> |
| ISO 8062:1984 | BS 6615:1985 <i>Specification for dimensional tolerances for metal and metal alloy castings</i> |

¹⁾ EN 29002:1987 has been superseded by EN ISO 9002:1994, which is identical with BS EN ISO 9002:1994.

Contents

| | Page |
|--|--------------------|
| Cooperating organizations | Inside front cover |
| National foreword | ii |
| Foreword | 2 |
| Text of EN 124 | 5 |
| National annex NA (informative) Committees responsible | Inside back cover |
| National annex NB (informative) Cross-references | Inside back cover |

National foreword

This British Standard has been prepared under the direction of the Technical Committee B/505, Waste Water Engineering and is the English language version of EN 124:1994.

EN 124 was produced as a result of European discussion in which the UK took an active part. The UK voted against this standard at the Formal Vote stage but the analysis of voting, in accordance with clause 5.1 of the Common CEN/CENELEC Rules, resulted in a positive vote. In consequence the document was accepted as a European Standard.

EN 124:1994 is a revision of EN 124:1986.

This British Standard supersedes BS 497-1:1976, which will be withdrawn in due course.

A British Standard does not purport to include all the necessary provisions of a contract. Users of British Standards are responsible for their correct application.

Compliance with a British Standard does not of itself confer immunity from legal obligations.

Summary of pages

This document comprises a front cover, an inside front cover, pages i and ii, the EN title page, pages 2 to 22, an inside back cover and a back cover.

This standard has been updated (see copyright date) and may have had amendments incorporated. This will be indicated in the amendment table on the inside front cover.

Descriptors: Sanitation, water removal, gully tops, closing devices, traffic lanes, specifications, classifications, equipment specifications, tests, quality control, marking

English version

Gully tops and manhole tops for vehicular and pedestrian
areas —
Design requirements, type testing, marking, quality control

Dispositifs de couronnement et de fermeture
pour les zones de circulation utilisées par les
piétons et les véhicules —
Principes de construction, essais types,
marquage, contrôle de qualité

Aufsätze und Abdeckungen für
Verkehrsflächen Baugrundsätze, Prüfungen,
Kennzeichnung, Gütebeurteilung

This European Standard was approved by CEN on 1994-06-06. CEN members are bound to comply with the CEN/CENELEC Internal Regulations which stipulate the conditions for giving this European Standard the status of a national standard without any alteration.

Up-to-date lists and bibliographical references concerning such national standards may be obtained on application to the Central Secretariat or to any CEN member.

This European Standard exists in three official versions (English, French, German). A version in any other language made by translation under the responsibility of a CEN member into its own language and notified to the Central Secretariat has the same status as the official versions.

CEN members are the national standards bodies of Austria, Belgium, Denmark, Finland, France, Germany, Greece, Iceland, Ireland, Italy, Luxembourg, Netherlands, Norway, Portugal, Spain, Sweden, Switzerland and United Kingdom.

CEN

European Committee for Standardization
Comité Européen de Normalisation
Europäisches Komitee für Normung

Central Secretariat: rue de Stassart 36, B-1050 Brussels

Foreword

The Technical Committee CEN/TC 77, Drainage equipment, was founded in 1973 and in the beginning it was concerned with general drainage equipment. As the tasks which had to be accomplished were revealed as being too extensive, the Committee was divided into the working groups, Drainage equipment inside buildings (WG 1), and Drainage equipment outside buildings (WG 2), and, finally, in 1980 two independent Technical Committees were created, i.e. CEN/TC 77, Drainage equipment (systems, design requirements, coordination) inside buildings, and CEN/TC 96, Drainage equipment outside buildings. In 1989 the two committees were put together again due to a draft mandate of the EEC and taking into account the new approach; the committee's number now is CEN/TC 165.

For the first edition of EN 124 published in 1986 the committee left certain requirements for later consideration. Also some other requirements, e.g. the selection of the class of the gully tops and manhole tops appropriate to the place of installation, could not be specified at that time.

In 1988 it was decided in CEN/TC 96 to revise the standard and to include the subject of certification. This and all the other requirements are now included in this revised version which was adopted by the TC 165 in 1993 but also at present the assignment of classes in relation to places of installation could only be given by a directive.

This European Standard shall be given the status of a national standard either by publication of an identical text or by endorsement, at the latest by December 1994, and conflicting national standards shall be withdrawn at the latest by December 1994.

According to the CEN/CENELEC Internal Regulations, the following countries are bound to implement this European Standard: Austria, Belgium, Denmark, Finland, France, Germany, Greece, Iceland, Ireland, Italy, Luxembourg, Netherlands, Portugal, Spain, Switzerland, United Kingdom.

Contents

| | |
|-------------------------|------|
| | Page |
| Foreword | 2 |
| 1 Scope | 5 |
| 2 Normative references | 5 |
| 3 Definitions | 5 |
| 4 Classification | 8 |
| 5 Place of installation | 8 |
| 6 Materials | 9 |

| | |
|--|----|
| 6.1 General | 9 |
| 6.1.1 Manhole tops and gully tops | 9 |
| 6.1.2 Gratings | 9 |
| 6.1.3 Other materials | 9 |
| 6.1.4 Cover fillings | 9 |
| 6.2 Production, quality and testing | 9 |
| 7 Design requirements | 9 |
| 7.1 General | 9 |
| 7.2 Vents in covers for manhole tops | 9 |
| 7.3 Clear openings of manhole tops for man entry | 10 |
| 7.4 Depth of insertion | 10 |
| 7.5 Total clearance | 10 |
| 7.6 Seatings | 10 |
| 7.7 Edge and contact surfaces protection for manhole tops of steel reinforced concrete | 10 |
| 7.8 Securing of the cover/grating within the frame | 10 |
| 7.9 Slot dimensions | 10 |
| 7.9.1 Straight slots | 11 |
| 7.9.1.1 Classes A 15 and B 125 | 11 |
| 7.9.1.2 Classes C 250 to F 900 | 11 |
| 7.9.2 Slots other than straight | 11 |
| 7.10 Dirt pans and dirt buckets | 11 |
| 7.11 Positioning of covers and gratings | 11 |
| 7.12 Surface condition | 11 |
| 7.13 Loosening and opening of covers and gratings | 11 |
| 7.14 Sealed manhole tops | 12 |
| 7.15 Frame bearing area | 12 |
| 7.16 Frame depth | 12 |
| 7.17 Opening angle of hinged covers/gratings | 12 |
| 7.18 Recessed covers (filled covers) | 12 |
| 8 Testing | 12 |
| 8.1 Test loads | 12 |
| 8.2 Testing apparatus | 13 |
| 8.2.1 Testing machine | 13 |
| 8.2.2 Test blocks | 13 |
| 8.2.3 Preparation for the test | 13 |
| 8.2.4 Type testing | 13 |
| 8.3 Testing procedure | 13 |
| 8.3.1 Measurement of permanent set of the cover or grating after the application of $\frac{2}{3}$ of the test load | 13 |

| | Page | | Page |
|--|------|--|------|
| 8.3.2 Application of the test load | 15 | Figure 7b | 7 |
| 8.4 Measurement control | 15 | Figure 7c | 7 |
| 8.4.1 General inspection | 15 | Figure 7d | 7 |
| 8.4.2 Vents | 15 | Figure 7e | 7 |
| 8.4.3 Clear opening | 15 | Figure 8a | 7 |
| 8.4.4 Depth of insertion | 15 | Figure 8b | 7 |
| 8.4.5 Total clearance | 15 | Figure 8c | 7 |
| 8.4.6 Seatings | 15 | Figure 9a — Typical highway | |
| 8.4.7 Edge protection | 15 | cross-section showing the location of | |
| 8.4.8 Securing of cover and/or | | some installation groups | 8 |
| grating within its frame | 15 | Figure 9b — Typical detail of a hard | |
| 8.4.9 Slot dimensions | 15 | shoulder showing the location of some | |
| 8.4.9.1 Straight slots | 15 | installation groups | 8 |
| 8.4.9.2 Slots other than straight | 15 | Figure 10 — Orientation of slots | 11 |
| 8.4.10 Dirt buckets, dirt pans | 16 | Figure 11 — Gauge | 12 |
| 8.4.11 Positioning | 16 | Figure 12 — Test blocks and geometric | |
| 8.4.12 Surface condition | 16 | centres | 15 |
| 8.4.13 Loosening and opening of covers | | Table 1 — Galvanizing coating of rolled | |
| and gratings | 16 | steel | 9 |
| 8.4.14 Frame depth | 16 | Table 2 — Minimum vent area | 9 |
| 8.4.15 Opening angle | 16 | Table 3 — Thickness of edge and contact | |
| 8.4.16 Permanent set | 16 | surface protection | 10 |
| 9 Marking | 16 | Table 4 — Dimensions for classes A 15 | |
| 10 Quality control | 16 | and B 125 | 11 |
| 10.1 General | 16 | Table 5 — Dimensions for classes C 250 | |
| 10.2 Quality control done by the | | to F 900 | 11 |
| manufacturer | 16 | Table 6 — Test loads | 13 |
| 10.2.1 Factories certified to EN 29002 | 16 | Table 7 — Dimensions of test blocks | 14 |
| 10.2.2 Factories not certified to EN 29002 | 16 | Table 8 — Permissible permanent set | 15 |
| 10.3 Third party control | 16 | Table 9 — Third party control | 18 |
| 10.3.1 Procedure of the 3rd party control | 17 | Table A.1 — Receiving inspection and testing | 19 |
| 10.3.1.1 Factories certified to EN 29002 | 17 | Table A.2 — Process control | 20 |
| 10.3.1.2 Factories not to certified | | Table A.3 — Final inspection and testing | |
| to EN 29002 | 17 | of products | 21 |
| 10.3.2 Report by the third party | 17 | Table A.4 — Rolled steel | 21 |
| 10.3.3 Nonconforming units | 17 | Table A.5 — Reinforced concrete | 22 |
| 11 Installation | 17 | Table A.6 — Inspection, measuring and | |
| Annex A (normative) Scheme of | | test equipment — Handling, storage, | |
| internal quality control | 19 | packaging and delivery — Control of | |
| Figure 1 | 6 | nonconforming product | 22 |
| Figure 2 | 6 | | |
| Figure 3 | 6 | | |
| Figure 4 | 6 | | |
| Figure 5 | 6 | | |
| Figure 6 | 7 | | |
| Figure 7a | 7 | | |

1 Scope

This standard applies to gully tops and manhole tops with a clear opening up to and including 1 000 mm, for installation within areas subjected to pedestrian and/or vehicular traffic. This standard does not apply to surface boxes nor to floor and roof gullies in buildings which are specified in prEN 1253.

The purpose of this standard is to establish definitions, classes, materials, design and testing requirements, marking and quality control of gully tops and manhole tops.

2 Normative references

This European Standard incorporates by dated or undated references, provisions from other publications. These normative references are cited at the appropriate places in the text and the publications are listed hereafter. For dated references, subsequent amendments to or revisions of any of these publications apply to this European Standard only when incorporated in it by amendment or revision. For undated references the latest edition of the publication referred to applies.

ISO 185:1988, *Grey cast iron — Classification.*

ISO 1083:1987, *Spheroidal graphite cast iron — Classification.*

ISO 630:1980, *Structural steels.*

ISO 3755:1991, *Cast carbon steels for general engineering purposes.*

ISO 1459:1973, *Metallic coatings — Protection against corrosion by hot dip galvanizing — Guiding principles.*

ISO 1460:1992, *Metallic coatings — Hot dip galvanized coatings on ferrous materials — Gravimetric determination of the mass per unit area.*

ISO 1461:1973, *Metallic coatings — Hot dip galvanized coatings on fabricated ferrous products — Requirements.*

ISO 8062:1984, *Castings — System of dimensional tolerances.*

Euronorm 80:1985, *Reinforcing bars (not for prestressing); Technical delivery conditions.*

Euronorm 81:1969.03, *Hot rolled flat round reinforcing steel; dimension, mass, tolerances.*

Euronorm 82:1979.02, *Steel for the reinforcement of concrete with an improved bonding action; dimensions, mass, tolerances, general requirements.*

prEN 1253-1, *Gullies for buildings — Part 1: Requirements.*

prEN 1253-2, *Gullies for buildings — Part 2: Test methods.*





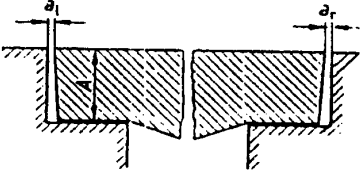
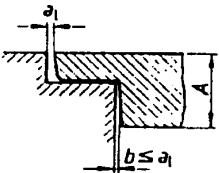
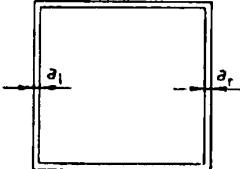
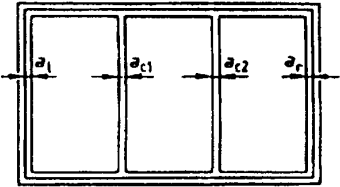
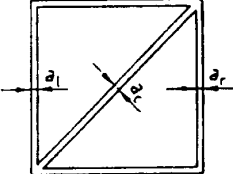

EN 29002:1987, *Quality systems — Model for quality assurance in production and installation.*

3 Definitions

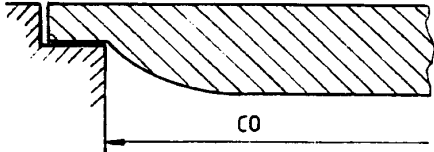
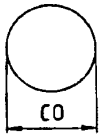
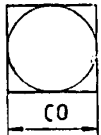
For the purposes of this standard the following definitions apply.

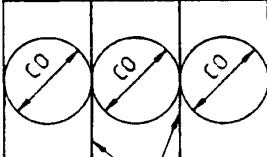
| No. | Term | Definition |
|-----|-------------|--|
| 1 | Gully | An assembly to receive surface water for discharge into a drainage system |
| 2 | Manhole | A chamber or access shaft to underground systems |
| 3 | Gully top | That part of a gully, consisting of a frame and grating and/or cover and which is placed on the gully pot at the place of installation |
| 4 | Manhole top | That part of a manhole consisting of a frame and a cover and/or a grating |
| 5 | Frame | The fixed part of a gully top or manhole top which receives and supports a grating and/or a cover |
| 6 | Grating | The movable part(s) of a manhole top or a gully top, which permits the passage of water through itself to the gully |
| 7 | Cover | The movable part(s) of a manhole top or a gully top which cover(s) the manhole or gully opening |
| 8 | Vent | An opening in the cover of a manhole top to provide ventilation |
| 9 | Dirt bucket | A removable component of a gully or a gully top which collects debris |
| 10 | Dirt pan | A removable component of a manhole or manhole top which collects debris |
| 11 | Seating | The surface on which the grating or the cover rests in the frame |

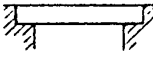
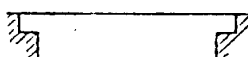
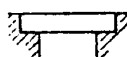
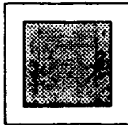
| No. | Term | Definition |
|-----|---------------------------------|--|
| 12 | Depth of insertion (A) (mm) | <p>The dimension A as shown in Figure 1 and Figure 2</p> <div style="display: flex; justify-content: space-around; align-items: center;">   </div> <div style="display: flex; justify-content: space-around; margin-top: 10px;"> Figure 1 Figure 2 </div> |
| 13 | Total clearance (a) (mm) | <p>The sum of the maximum individual clearances between adjacent elements of the frame and grating/cover as shown in Figure 1, Figure 2, Figure 3, Figure 4 and Figure 5</p> <p>$a = a_l + a_r$ in the case of Figure 3</p> <p>$a = a_l + a_{c1} + a_{c2} + a_r$ in the case of Figure 4</p> <p>$a = a_l + a_c + a_r$ in the case of Figure 5</p> <p>(a_l clearance left)</p> <p>(a_c clearance centre)</p> <p>(a_r clearance right)</p> <div style="display: flex; justify-content: space-around; align-items: center; margin-top: 20px;">   </div> <div style="display: flex; justify-content: space-around; margin-top: 10px;"> Figure 3 Figure 4 </div> <div style="display: flex; justify-content: center; align-items: center; margin-top: 20px;">  </div> <div style="display: flex; justify-content: center; margin-top: 10px;"> Figure 5 </div> |
| 14 | Bearing area (mm ²) | <p>The surface of the underside of a frame which rests upon the supporting structure</p> |

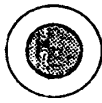
| No. | Term | Definition |
|-----|---|--|
| 15 | Clear opening (CO) (mm) | <p>The diameter of the largest circle that can be inscribed in the clear area (No. 16) of the frame, as shown in Figure 6 and Figure 7 a – Figure 7 e</p>  <p style="text-align: center;">Figure 6</p>  <p style="text-align: center;">Figure 7 a</p>  <p style="text-align: center;">Figure 7 b</p>  <p style="text-align: center;">Figure 7 c</p>  <p style="text-align: center;">Fixed bars Figure 7 d</p>  <p style="text-align: center;">Figure 7 e</p> |
| 16 | clear area (m ²) | <p>The unobstructed area between the seatings i.e. the shaded area as shown in Figure 8 a, Figure 8 b, Figure 8 c</p>     <p style="text-align: center;">Figure 8 a</p>  <p style="text-align: center;">Figure 8 b</p>  <p style="text-align: center;">Figure 8 c</p> |
| 17 | Mass per unit area (kg/m ²) | Total mass of the cover or the grating in kg divided by the clear area in m ² |
| 18 | Cushioning insert | Material in a frame, grating or cover used to provide a non-rock seating |
| 19 | Test load (kN) | Load applied to gully tops or manhole tops when tested |
| 20 | Pedestrian areas | Area reserved for pedestrians and only occasionally open to vehicular traffic for delivery, cleaning purposes or in emergency |
| 21 | Pedestrian streets | Area where vehicular traffic is prohibited during certain periods (e.g. pedestrian areas during business hours and vehicular traffic outside these hours) |

4 Classification

Gully tops and manhole tops are divided into the following classes:

A 15, B 125, C 250, D 400, E 600 and F 900.

NOTE When the standard is revised in the future, the conversion of class A 15 to A 30 may be considered.

5 Place of installation

The appropriate class of manhole top or gully top to be used depends upon the place of installation. The various places of installation have been divided into groups numbered 1 to 6, as listed below. Figure 9a and Figure 9b show the location of some of these groups in a highway environment. A guide as to which class of manhole top or gully top should be used is shown in parentheses for each group. The selection of the appropriate class is the responsibility of the designer. Where there is any doubt, the stronger class should be selected.

Group 1 (min. class A 15)

Areas which can only be used by pedestrians and pedal cyclists.

Group 2 (min. class B 125)

Footways, pedestrian areas and comparable areas, car parks or car parking decks.

Group 3 (min. class C 250)

For gully tops installed in the area of kerbside channels of roads (Figure 9a) which when measured from the kerb edge, extend a maximum of 0,5 m into the carriageway and a maximum of 0,2 m into the footway.

Group 4 (min. class D 400)

Carriageways of roads (including pedestrian streets), hard shoulders (Figure 9b) and parking areas, for all types of road vehicles.

Group 5 (min. class E 600)

Areas imposing high wheel loads, e.g. docks, aircraft pavements.

Group 6 (class F 900)

Areas imposing particularly high wheel loads, e.g. aircraft pavements.

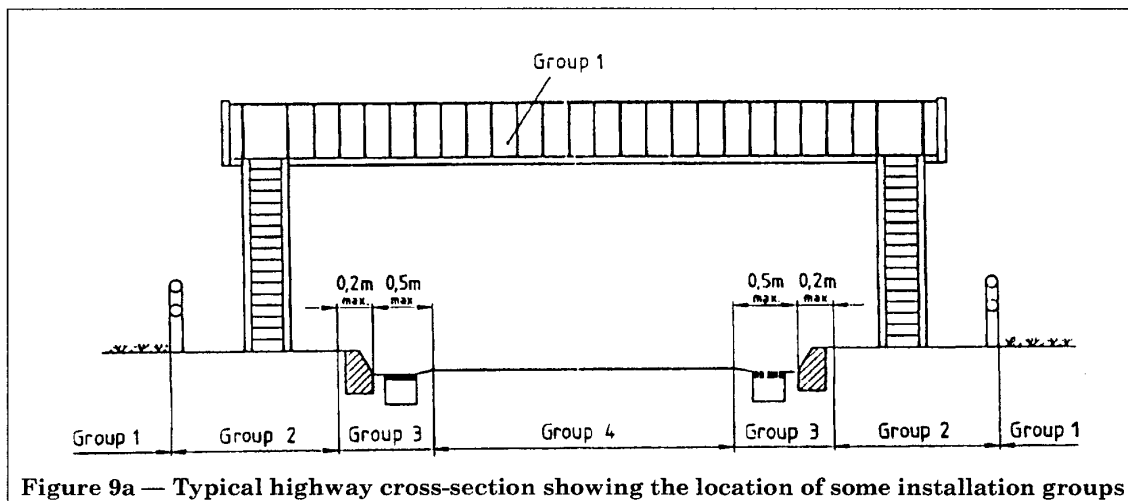

Figure 9a — Typical highway cross-section showing the location of some installation groups

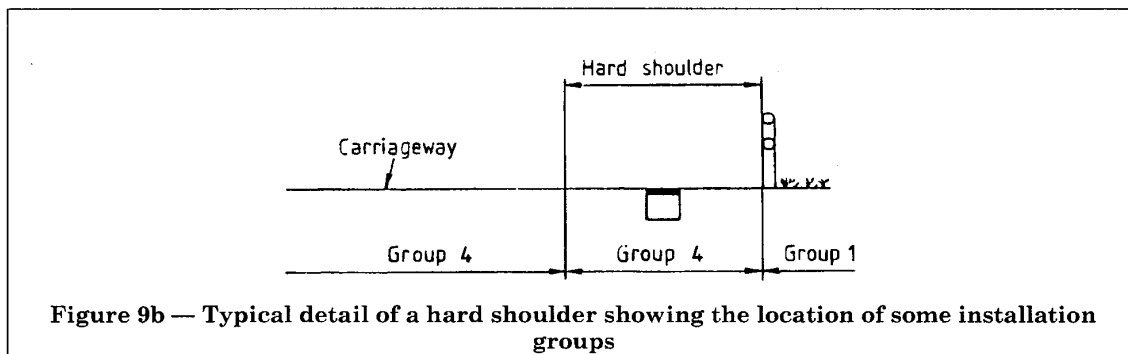

Figure 9b — Typical detail of a hard shoulder showing the location of some installation groups

6 Materials

6.1 General

6.1.1 Manhole tops and gully tops

Manhole tops and gully tops with the exception of gratings shall be made from either:

- flake graphite cast iron;
- spheroidal graphite cast iron;
- cast steel;
- rolled steel;
- one of the materials a) to d) combined with concrete; or
- steel reinforced concrete.

The use of rolled steel is admissible only if a sufficient corrosion resistance is ensured. This resistance can be achieved by hot-dip galvanizing on a clean surface with a thickness of equal or greater than the values given in Table 1. The minimum thickness of rolled steel shall be 2,75 mm (except for contact and edge protection which shall comply with 7.7)

Table 1 — Galvanizing coating of rolled steel

| Steel thickness mm | Minimum coating thickness μm | Minimum coating mass g/m^2 |
|-----------------------|---|---|
| $\geq 2,75$ to < 5 | 50 | 350 |
| ≥ 5 | 65 | 450 |

6.1.2 Gratings

Gratings shall be made from either:

- flake graphite cast iron;
- spheroidal graphite cast iron; or
- cast steel.

6.1.3 Other materials

For any other material used in the field of application of this standard, all requirements of this specification shall be met and an approved independent body shall establish any other relevant requirements and testing methods.

6.1.4 Cover fillings

Cover fillings may consist of concrete or other filling material appropriate to the place of installation.

6.2 Production, quality and testing

The production, quality and testing of the materials designated below shall comply with the following ISO standards or Euronorms:

| | | |
|-------------------------------|----------|------|
| Flake graphite cast iron | ISO 185 | 1988 |
| Spheroidal graphite cast iron | ISO 1083 | 1987 |

| | | |
|--------------------------|-------------|---------|
| Rolled steel | ISO 630 | 1980 |
| Cast steel | ISO 3755 | 1991 |
| Hot dip galvanizing | ISO 1459 | 1973 |
| | ISO 1460 | 1992 |
| | ISO 1461 | 1973 |
| Tolerances for cast iron | ISO 8062 | 1984 |
| Reinforcing steel | Euronorm 80 | 1985.03 |
| | Euronorm 81 | 1969.03 |
| | Euronorm 82 | 1979.02 |

The minimum compressive strength of concrete for classes B 125 to F 900 at 28 days shall be 45 N/mm^2 for a test cube of 150 mm, or 40 N/mm^2 for a test cylinder 150 mm diameter \times 300 mm high. For class A 15 manhole tops, the minimum compressive strength shall be 25 N/mm^2 .

When steel reinforcement is used, the concrete cover to the steel shall be a minimum of 20 mm on all sides. The reinforcement design and detailing shall be in accordance with the relevant European Standards. This does not apply to manhole covers which have a bottom plate of steel, cast steel, flake graphite iron or spheroidal graphite iron.

7 Design requirements

7.1 General

Gully tops and manhole tops shall be free of defects which might impair their fitness for use.

Where there is no detailed specification shown in this standard for any particular requirement, the manufacturer shall state such specification in his documentation.

When metal is used in combination with concrete or any other material, there shall be adequate bond between the two materials.

7.2 Vents in covers for manhole tops

Manhole tops may be designed with or without vents.

For manhole tops with vents the minimum vent area shall be as given in Table 2.

Table 2 — Minimum vent area

| Clear opening | Minimum vent area |
|-----------------------|--|
| $\leq 600 \text{ mm}$ | 5 % of the area of a circle having a diameter equal to the clear opening |
| $> 600 \text{ mm}$ | 140 cm^2 |

Vents in the covers for manhole tops shall have the following dimensions:

a) slots:

| | |
|--------|---|
| length | ≤ 170 mm |
| width | 18 mm to 25 mm for classes A 15 and B 125 |
| width | 18 mm to 32 mm for classes C 250 to F 900 |

b) holes:

| |
|--|
| 18 mm to 38 mm diameter for classes A 15 and B 125 |
| 30 mm to 38 mm diameter for classes C 250 to F 900 |

For manhole tops with vents, dirt pans may be required.

NOTE The purchaser or specifying authority should state on the enquiry or on the order to the manufacturer, if manhole tops are required to have vents and if dirt pans are required.

7.3 Clear openings of manhole tops for man entry

The opening of manhole tops designed for man entry shall comply with the safety requirements in force at the place of installation. Generally this is considered to be at least 600 mm diameter.

7.4 Depth of insertion

Gully tops and manhole tops of classes D 400, E 600 and F 900 shall have a depth of insertion *A* (see clause 3, No. 12) of at least 50 mm.

This requirement does not apply if the covers or gratings are made secure in their position against displacement by traffic by a locking device but such devices are not included in this standard.

7.5 Total clearance

The clearance between the different parts of gully tops and manhole tops is defined in clause 3, No. 13.

The dimension *b* shall be equal to or less than dimensional α_1 (see clause 3, Figure 2).

This clearance may lead to horizontal displacement of the cover or grating in its frame. In order to limit this displacement, the total clearance *a* shall comply with the following requirements:

- for covers or gratings in one or two parts; clear opening ≤ 400 mm $a \leq 7$ mm
- clear opening > 400 mm $a \leq 9$ mm
- for covers or gratings with three or more parts, the total clearance *a* resulting from the displacement of all parts shall not exceed 15 mm, with each individual clearance limited to a maximum of 5 mm.

7.6 Seatings

The manufacture of gully tops and manhole tops shall be such as to ensure the compatibility of their seatings. For classes D 400 to F 900 these seatings shall be manufactured in such a way as to ensure stability and quietness in use. This may be achieved by machining of the contact surfaces, use of cushioning inserts, three-point suspension design or any other appropriate method.

7.7 Edge and contact surfaces protection for manhole tops of steel reinforced concrete

For manhole tops of classes A 15 to D 400 of steel reinforced concrete, edges and contact surfaces between frame and cover shall be protected with cast iron or hot-dip galvanized steel. The minimum thickness of flake graphite iron, spheroidal graphite iron or steel is stated in Table 3.

Table 3 — Thickness of edge and contact surface protection

| Class | Minimum thickness of the cast iron or the steel protection ^a mm |
|-------|---|
| A 15 | 2 |
| B 125 | 3 |
| C 250 | 5 |
| D 400 | 6 |
| E 600 | To be determined according to each design |
| F 900 | To be determined according to each design |

^a Without the thickness of the additional corrosion protection.

7.8 Securing of the cover/grating within the frame

The cover/grating shall be secure within its frame to meet the required traffic conditions relevant to the place of installation defined in clause 5.

This may be achieved by one of the following arrangements:

- a) a locking device;
- b) a sufficient mass per unit area;
- c) a specific design feature.

These arrangements shall be designed so as to allow opening of the covers or gratings by means of usual tools.

NOTE Constructional types which are usual in the different countries remain valid until harmonization of the arrangements mentioned in a) to c).

7.9 Slot dimensions

The dimensions of slots in gratings shall be selected having regard to the hydraulic capacity and the slots shall be evenly distributed over the clear area. The water way area shall not be less than 30 % of the clear area and shall be given in the manufacturer's catalogue.

7.9.1 Straight slots

7.9.1.1 Classes A 15 and B 125

The slots of gratings for classes A 15 and B 125 shall have the dimensions stated in Table 4.

Table 4 — Dimensions for classes A 15 and B 125

| Width mm | Length mm |
|-------------|---------------|
| 8 to 18 | No limitation |
| > 18 to 25 | ≤ 170 |

NOTE In pedestrian areas, the slot may be reduced to 5 mm at the specifier's discretion.

7.9.1.2 Classes C 250 to F 900

The dimensions of slots for classes C 250 to F 900 shall be dependent on the orientation of the longitudinal axis of the slots in relation to the direction of traffic, in accordance with Table 5 and Figure 10.

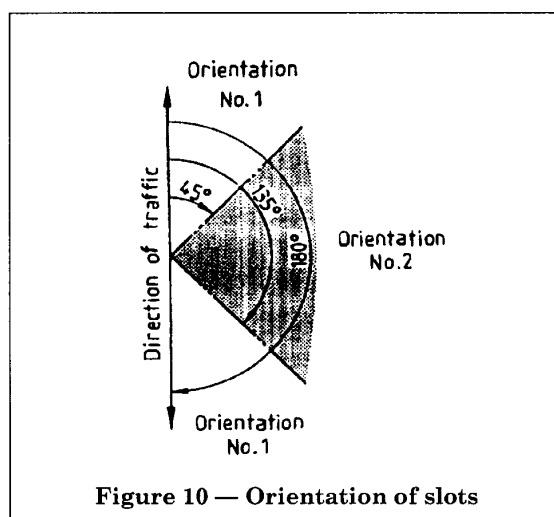

Figure 10 — Orientation of slots

7.9.2 Slots other than straight

Slots other than straight shall be designed in such a way as to prevent a $170 \times 170 \times 20$ mm gauge from entering the slot.

7.10 Dirt pans and dirt buckets

Where dirt pans or dirt buckets are used it shall be ensured that drainage and ventilation can continue with the dirt pan or bucket filled.

NOTE The purchaser or specifying authority should state on the enquiry or on the order to the manufacturer, whether or not dirt pans or dirt buckets are required.

7.11 Positioning of covers and gratings

Where the cover or grating has to be in a predetermined position relative to the frame, this is to be ensured by an appropriate design.

7.12 Surface condition

The upper surface of gratings, covers and frames of classes D 400 to F 900 shall be flat within a tolerance of 1 % of the clear opening with a maximum of 6 mm. An exception to this requirement is permitted in the case of D 400, which may have a concave surface if they are installed in parking areas as described in clause 5, group 4.

New solid cast iron and cast steel upper surface(s) of manhole tops shall have a raised pattern.

Height of raised pattern:

— for class A 15, B 125 and C 250: 2 to 6 mm

— for class D 400, E 600 and F 900: 3 to 8 mm

Surface area of raised pattern:

— the surface area of the raised pattern shall not be less than 10 % and no more than 70 % of the total upper surface area.

7.13 Loosening and opening of covers and gratings

Provision shall be made for the effective loosening and for the opening of the covers and gratings; such provisions are not included in this standard.

Table 5 — Dimensions for classes C 250 to F 900

| Orientation | | Class mm | Width mm | Length mm |
|-------------|--|----------------|-------------|---------------|
| No. 1 | From 0° to $< 45^\circ$ and from $> 135^\circ$ to 180° | All classes | 16 to 32 | ≤ 170 |
| No. 2 | From 45° to 135° | C 250 | 16 to 42 | No limitation |
| | | D 400 to F 900 | 20 to 42 | No limitation |

7.14 Sealed manhole tops

In certain circumstances, some manhole tops should be sealed. The sealing design depends upon the pressure underneath the cover and the requirements in that specific situation. These requirements may include odourtightness, gastightness or water pressure tightness.

NOTE The design of this sealing feature is not included in this standard and the types which are used in different countries remain valid until harmonization.

7.15 Frame bearing area

The bearing area shall be designed in such a way that:

- the bearing pressure in relation to the test load shall not exceed $7,5 \text{ N/mm}^2$; and
- it provides an adequate contribution to stability under working conditions.

7.16 Frame depth

The depth of the complete frame of manhole or gully tops of class D 400, E 600 and F 900 shall be at least 100 mm, except the metal part for class D 400 which may be reduced to 75 mm provided that:

- the frame shall be cast into a concrete collar of strength at least B 45 in such a way as to achieve a bond between the frame and the concrete; or
- the frame is provided and fixed with anchoring devices.

NOTE Pending the publication of a CEN code on the installation of manhole tops or gully tops, the specifier may require a frame deeper than 100 mm, appropriate to the particular traffic flow characteristics of the method of installation (see clause 11).

7.17 Opening angle of hinged covers/gratings

The opening angle of hinged covers or gratings shall be at least 100° to the horizontal unless otherwise specified.

Where hinged covers or gratings have a radially profiled edge on the hinged side, it shall be profiled so that the gauge of $170 \times 170 \times 20 \text{ mm}$, detailed in Figure 11, is prevented from entering the gap between the adjacent frame and the curved edge of the cover or grating by more than 13 mm of its 170 mm depth, the gauge being vertical with its length parallel to the profiled edge.

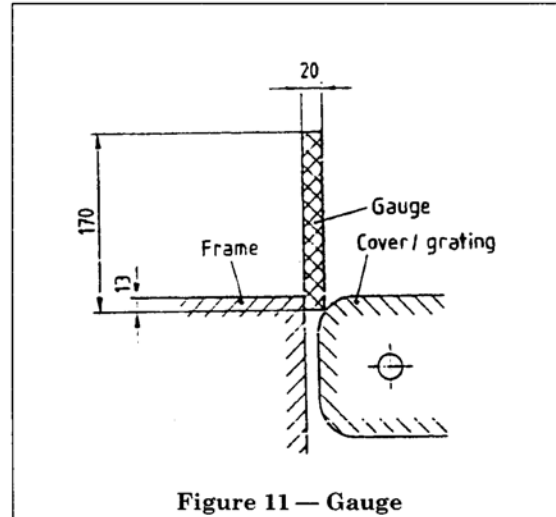

Figure 11 — Gauge

7.18 Recessed covers (filled covers)

In the case of recessed covers, the manufacturer shall provide all necessary specifications for filling, unless the filling is carried out at the manufacturer's plant.

The surface texture of such filled covers shall be appropriate to the place of installation.

8 Testing

Gully tops and manhole tops shall be tested as complete units in their condition of service except for recessed covers delivered unfilled, which shall be load tested without filling.

Compliance with the loading requirements for the appropriate class (see clause 4) shall be determined by a loading test (see Table 6).

Additional tests may be required for gully tops and manhole tops made of other materials not listed in clause 6.

Where there is no detailed test method for the verification of any requirement in this standard, the manufacturer shall state in his documents how such verification is achieved (see 7.1, 2nd paragraph).

8.1 Test loads

For gully tops and manhole tops with a clear opening (CO) equal to or greater than 250 mm, the test load is shown in Table 6 for each class. Where the clear opening (CO) is less than 250 mm, the test load shall be that shown in Table 6, multiplied by CO/250.

Table 6 — Test loads

| Class | Test load kN |
|-------|-----------------|
| A 15 | 15 |
| B 125 | 125 |
| C 250 | 250 |
| D 400 | 400 |
| E 600 | 600 |
| F 900 | 900 |

8.2 Testing apparatus

8.2.1 Testing machine

The testing machine, preferably a hydraulic test press, shall be capable of applying a load at least 25 % greater than the respective test load for classes A 15 to D 400, and at least 10 % greater than the respective test load for classes E 600 and F 900. A tolerance of ± 3 % of the test load shall be maintained.

Except for multiple units, the dimensions of the bed of the testing machine shall be greater than the bearing area of the unit to be tested.

8.2.2 Test blocks

The dimensions and shapes of test blocks are shown in Table 7.

8.2.3 Preparation for the test

The test block shall be placed on the unit with its vertical axis perpendicular to the surface and coincidental with the geometric centre of the cover or the grating (examples, see Figure 12). In the case of double triangular covers or gratings, the test block shall be positioned in the geometric centre, as shown in Figure 12. The cover or grating shall rest normally in the frame.

The test load shall be uniformly distributed over the whole surface of the test block and any irregularities compensated for by means of an appropriate intermediate layer, e.g. softwood, fibre board, felt or similar material positioned between the cover or the grating and the test block. The dimensions of this intermediate layer shall be not larger than those of the test block. A similar intermediate layer, at the manufacturer's option, may also be positioned between the bed of the testing machine and the bearing area.

When testing gully tops or manhole tops with a non-flat surface the contact face of the test block shall be shaped to match the grating or cover. Patterns as defined in 7.12 and small deviations from a flat surface do not require a shaped contact face of the test block.

8.2.4 Type testing

Three test specimens shall be tested, to prove that they meet the appropriate requirements, before the manufacturer applies for third party certification. Each specimen shall comply with all the requirements of clauses 6, 7, 8 and 9.

This procedure shall also apply if the design is structurally subsequently amended. All subsequent amendments whether structural or not must have the approval of the certification body.

8.3 Testing procedure

All gully tops and manhole tops shall be submitted to the following tests:

- measurement of the permanent set of the cover or grating after the application of $2/3$ of the test load (subclause 8.3.1);
- application of the test load (subclause 8.3.2).

8.3.1 Measurement of permanent set of the cover or grating after the application of $2/3$ of the test load

Before the load is applied, take an initial reading at the geometric centre of the cover or grating.

The load shall be applied at a rate of 1 kN/s to 5 kN/s up to $2/3$ of the test load; the load on the test specimen is then released. This procedure shall be carried out five times. Then take a final reading at the geometric centre.

The permanent set shall then be determined as the difference of the measured readings before the first and after the fifth loading. The permanent set shall not exceed the values given in Table 8.

In the case of double triangular covers or gratings, the permanent set shall be measured on both parts, as close as possible to the geometric centre (see 8.2.3, Figure 12).

Table 7 — Dimensions of test blocks

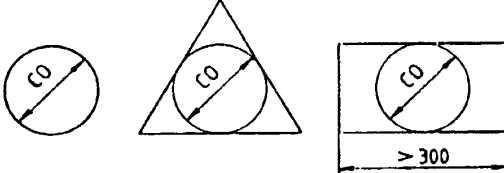
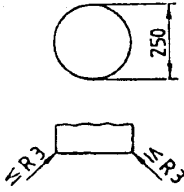
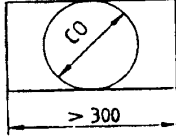
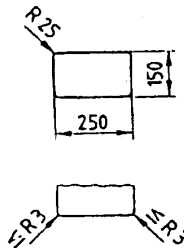
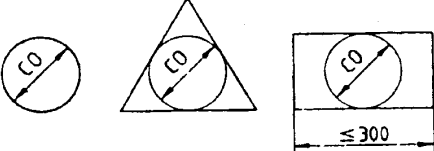
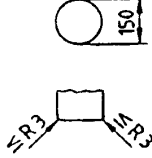
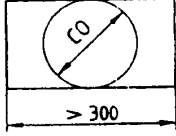
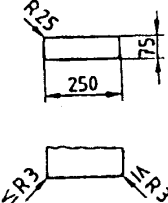
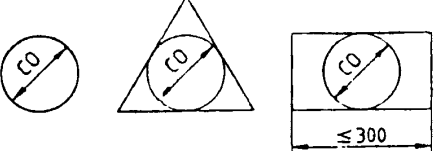
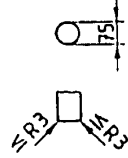
| Shape and clear opening of the gully tops or the manhole tops mm | Dimensions of the test blocks mm |
|--|--|
| <p>300 < CO ≤ 1 000</p>  |  |
| <p>200 ≤ CO ≤ 300</p>  |  |
| <p>200 ≤ CO ≤ 300</p>  |  |
| <p>CO < 200</p>  |  |
| <p>CO < 200</p>  |  |

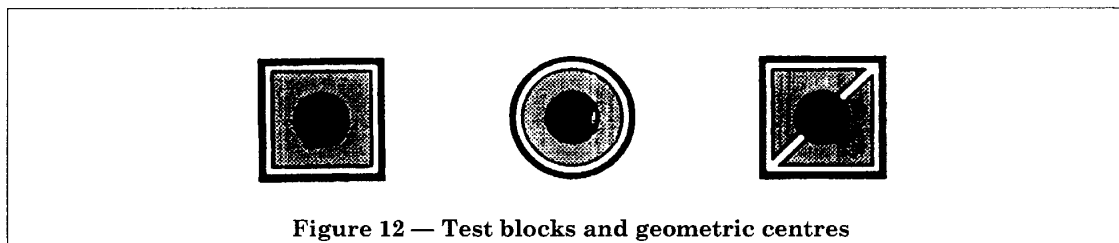

Figure 12 — Test blocks and geometric centres

Table 8 — Permissible permanent set

| Class | Permissible permanent set | |
|--|---|---|
| A 15 and B 125 | $\frac{1}{100}$ CO ^a | |
| C 250 up to F 900 | $\frac{1}{300}$ CO ^b When secured according to 7.8 a) or 7.8 c) | $\frac{1}{500}$ CO ^c When secured according to 7.8 b) |
| ^a $\frac{CO}{50}$ when CO < 450 mm. ^b 1 mm max. when CO < 300 mm. ^c 1 mm max. when CO < 500 mm. | | |

For test specimens of steel reinforced concrete, no cracks wider than 0,2 mm shall appear in the concrete after this test. Crack widths shall be measured by the insertion of feeler gauges or other appropriate means.

8.3.2 Application of the test load

Immediately after the test according to 8.3.1, the test load shall be applied at the same rate given in 8.3.1, until it is achieved. The test load to be maintained for 30_0^{+2} s. Units made of materials a) to e) of clause 6 shall not show cracks in the course of the test. In the case of steel reinforced concrete covers there shall be no loss of adhesion between the concrete and the reinforcing steel.

8.4 Measurement control

8.4.1 General inspection (see 7.1)

All products shall be visually inspected for defects.

8.4.2 Vents (see 7.2)

Vent slots and holes shall be measured to an accuracy of 1 mm. The vent area shall be calculated to the nearest 100 mm².

8.4.3 Clear opening (see 7.3)

The dimensions of the clear opening (circular, rectangular or triangular) shall be measured in millimetres.

8.4.4 Depth of insertion (see 7.4)

For classes D 400 to F 900 the depth of insertion (A) shall be measured in millimetres.

8.4.5 Total clearance (see 7.5)

The clearances between covers or gratings and frames shall be measured to an accuracy of 0,5 mm and the total clearance (a) shall be calculated.

8.4.6 Seatings (see 7.6)

The compatibility of the seatings to ensure stability of the cover or grating within its frame shall be inspected to the specification of the manufacturer.

8.4.7 Edge protection (see 6.1.1 and 7.7)

The thickness of the uncoated iron or steel edge protection to steel reinforced concrete manhole tops shall be measured to an accuracy of 0,1 mm. The thickness of the hot dip galvanizing shall be measured to accuracy of 5 μm.

8.4.8 Securing of the cover and/or grating within its frame (see 7.8)

- If securing is achieved by mass per unit area (see 7.8 b) the cover and/or grating shall be weighed to an accuracy of 1 % and the clear area calculated to an accuracy of 100 mm².
- If securing is achieved by a locking device or a specific design feature (see 7.8 a) or 7.8 c) the relevant arrangements shall be visually inspected, and measured if applicable.

8.4.9 Slot dimensions (see 7.9)

The even distribution of the slots over the clear area shall be visually inspected. The slots shall be measured to an accuracy of 1 mm and the waterway surface area calculated to an accuracy of 100 mm².

8.4.9.1 Straight slots (see 7.9.1.1 and 7.9.1.2)

The dimensions of straight slots shall be measured to an accuracy of 1 mm.

8.4.9.2 Slots other than straight (see 7.9.2)

The dimensions of slots other than straight shall be controlled by a gauge of 170 × 170 × 20 mm.

8.4.10 Dirt buckets, dirt pans (see 7.10)

The dirt bucket/pan shall be filled with sand before it is visually inspected to ensure that both drainage and ventilation is still possible.

8.4.11 Positioning (see 7.11)

If an indelible mark or register is necessary to ensure a predetermined position to the cover and/or grating within the frame, this mark or register shall be visually inspected.

8.4.12 Surface condition (see 7.12)

The flatness shall be measured to an accuracy of 0,5 mm. The height of the raised pattern shall be measured to an accuracy of 0,5 mm. The total raised area of the cover and frame shall be determined either by reference to the drawing and subsequently controlled by visual inspection, or by measuring the dimensions of the upper surface of the raised pattern to an accuracy of 1 mm. The percentage ratio of the raised surface to the total area shall be calculated.

8.4.13 Loosening and opening of covers and gratings (see 7.13)

The loosening and opening facilities of covers and gratings shall be tested physically.

8.4.14 Frame depth (see 7.16)

The depth of the complete frame shall be measured to an accuracy of 1 mm.

8.4.15 Opening angle (see 7.17)

The opening angle shall be measured to an accuracy of 5°. When a hinged cover or grating has a radially profiled edge the profile shall be controlled by a gauge of 170 × 170 × 20 mm and the depth of entry shall be measured to an accuracy of 1 mm.

8.4.16 Permanent set (see 8.3.1)

The permanent set shall be measured to an accuracy of 0,1 mm.

9 Marking

All covers, gratings and frames shall bear:

- a) EN 124 (as the marking of this European Standard);
- b) the appropriate class (e.g. D 400) or classes for frames which can be used for several classes (e.g. D 400-E 600);
- c) the name and/or identification mark of the manufacturer and the place of manufacture which may be in code;
- d) the mark of a certification body; and may bear:
- e) additional markings relating to the application or the owner;

- f) product identification (name and/or catalogue number).

The above mentioned markings shall be clear and durable. They shall, where possible, be visible after the unit is installed.

10 Quality control**10.1 General**

Products manufactured to this standard shall be subjected to quality control procedures as follows:

- a) quality control undertaken by the manufacturer (see 10.2);
- b) inspection undertaken by an independent certification body (third party, see 10.3). For a new production unit, this inspection shall be undertaken, at the request of the manufacturer, within a 12 month period of its commissioning.

10.2 Quality control carried out by the manufacturer

The purpose of quality control is to ensure that the production of gully tops and manhole tops conforms to the technical requirements of this standard.

The facilities necessary for quality assurance shall include the test equipment for control based on the requirement of this standard.

The manufacturer's quality control documentation shall include details of all steps of production from the arrival of the raw materials through to the final product leaving the factory.

10.2.1 Factories certified to EN 29002

Quality control carried out by the manufacturer shall ensure compliance of the products.

10.2.2 Factories not certified to EN 29002

Annex A shall be the minimum prerequisite to the products certification. The manufacturer's quality control documentation shall be retained so that it is available for inspection by the third party inspector for 1 or 5 years as shown in Table A.1 to Table A.6 of annex A.

10.3 Third party control

The purpose of the third party control is:

- to ensure that the quality level of the product is continuously maintained according to the requirements of this standard, and;
- to give independent certification to the products.

10.3.1 Procedure of the third party control

10.3.1.1 Factories certified to EN 29002

The procedure for third party control shall consist of:

- controlling the validity of the licence granted to the manufacturer for compliance of his Quality Assurance System with EN 29002;
- verifying that the results of the controls made by the manufacturer are in compliance with the requirements of this standard;
- independent testing of the finished products.

The inspection of the third party control shall be undertaken without previous announcement at least twice a year, at regular intervals.

10.3.1.2 Factories not certified to EN 29002

Factories not certified to EN 29002 shall meet the requirements of annex A. The inspection of the third party control shall be undertaken without previous announcement, at least six times a year at regular intervals.

The procedure for third party control shall consist of:

- assessing the adequacy of the staff and equipment for continuous and orderly manufacture;
- verifying that type testing has been satisfactorily carried out in accordance with the requirements of this standard (see 8.2.4);
- verifying that quality control is independent of production; and
- independent testing of finished products.

The inspection may be reduced to four times a year provided that the independent certification body is satisfied that:

- the manufacturer's internal quality control system is adequate;
- the controls have been continuously carried out in a proper and effective way for three years; and
- the results are in compliance with the requirements of this EN.

This reduced frequency may remain valid for as long as no defective products are detected.

The third party shall ensure that the manufacturer's control and tests have been carried out in compliance with this standard, and that the results obtained have also met its requirements (see annex A).

The main aspects of third party verification are given in Table 9.

10.3.2 Report by the third party

The results of the third party control shall be given in a written report. The manufacturer shall sign this report. If the manufacturer does not agree with this report, he will discuss it with the Inspector. If no agreement can be reached, the manufacturer will sign the report and state his reservations thereon.

This report shall also contain at least the following items:

- the name of the manufacturer;
- the name and location of the factory;
- date, location and the signature of the manufacturer;
- the Quality Inspector's signature.

It shall further contain:

- a) for factories certified to EN 29002, a statement regarding
 - the validity of the certificate covering the quality system, and
 - conformity of these products
- b) for factories not certified to EN 29002, a statement regarding the results of the inspection in terms of:
 - staff
 - equipment
 - conformity of the products
 - Internal Quality Control

Within 3 weeks of the inspection, the official report shall be sent to the manufacturer by the independent third party control body.

10.3.3 Nonconforming units

If, during the third party inspection, a unit fails, 3 more units of the same type shall be tested. If one of these 3 fails the production related to the failure(s) shall be excluded from delivery, pending the outcome of further inspection. Within a period of 4 weeks or within a period to be agreed, the manufacturer shall be reassessed with respect to the nonconforming product, 6 of these products being tested. After the satisfactory testing of these 6 complete units, delivery may recommence.

11 Installation

Installation should be carried out in accordance with the relevant Code of Practice. Until such European Codes of Practice exist the National Code of Practice or the manufacturer's guide should be used.

Table 9 — Third party control

| Aspect of inspection | Method of inspection | Frequency of inspection | Documentation |
|---|------------------------------------|--------------------------------------|---------------|
| Receiving inspection | Table A.1 and Table A.5 | Every visit | In writing |
| Process control | Table A.2, Table A.4 and Table A.5 | Every visit | In writing |
| Final inspection and testing of products | Table A.3 | Every visit | In writing |
| — manhole tops | Clause 8 | 3 different complete types per visit | In writing |
| — gully tops | Clause 8 | 3 different complete types per visit | In writing |
| Inspection, measuring and test equipment | Table A.6 | Every visit | In writing |
| Handling, storage, packaging and delivery | Table A.6 | Every visit | In writing |
| Control of nonconforming product | Table A.6 | Every visit | In writing |
| Quality records | Visual | Every visit | In writing |

Annex A (normative)

Scheme of internal quality control

| | | | |
|---|--|---------------------|--|
| Field of application: | Gully tops and manhole tops for vehicular and pedestrian areas: EN 124 | | |
| Manufacturer: | name: | (IRONWORKS LIMITED) | |
| | place: | (FURNACE TOWN) | |
| | telephone no: | (123456) | |
| | telex no: | (7890) | |
| | fax no: | (654 321) | |
| Certificate no: | (34567) | | |
| Date of issue of certificate: | (.....) | | |
| List of certified products: | (see separate page[s]) | | |
| Document ref. no.: (A B C): | | | |
| Date of document issue: (1989-01-01) | Annexes: (× 1) | | |
| Revised on: (1990-05-08) (1991-11-12) (1992-12-03) (1993-08-12) | | | |
| Quality Control Manager: Mr Jan Ironheart | | | |
| Date: (1994-01-02) | Location of signatory (Brussels) | | |
| Signature of Manufacturer: (Mr S C R A P Cover) | | | |

Table A.1 — Receiving inspection and testing

| Flake graphite cast iron (see 6.1 a) and 6.1 g)) Spheroidal graphite cast iron (see 6.1 b) and 6.1 h)) Cast steel (see 6.1 c) and 6.1 i)) | | | |
|--|---|-------------------------|---------------------------|
| Aspect of inspection | Method of inspection | Frequency of inspection | Document retention period |
| Raw material storage area | Visually | Regularly | — |
| Iron ore | Cert supplier ^a | Every delivery | 1 year |
| Pig iron | Cert supplier ^a | Every delivery | 1 year |
| Scrap iron/steel (3rd party) | Cert supplier ^a | Every delivery | 1 year |
| Scrap returns (1st party) | IQC ^b | Every delivery | 1 year |
| Additives | Refer to the order | Every delivery | 1 year |
| Energy for melting: | | | |
| — Electricity | — | — | — |
| — Gas | Cert supplier ^a | Regularly/when changed | 1 year |
| — Coke | Cert supplier ^a | Every delivery | 1 year |
| Sand for moulds/cores | Cert supplier ^a and sieve analysis | Regularly | 1 year |
| Cushioning inserts | Cert supplier ^a | Every delivery | 1 year |
| Elastomere for cushioning inserts | Cert supplier ^a | Every delivery | 1 year |
| Sealing material | Cert supplier ^a | Every delivery | 1 year |
| ^a Certificate of the supplier: — deliveries from suppliers having a certified quality insurance system shall be subject to random control; — deliveries from suppliers having no certified quality insurance system shall be subject to a systematic control for each delivery. | | | |
| ^b IQC — Internal Quality Control. | | | |

Table A.2 — Process control

| Flake graphite cast iron (see 6.1 a) and 6.1 g) Spheroidal graphite cast iron (see 6.1 b) and 6.1 h) Cast steel (see 6.1 c) and 6.1 i)) | | | |
|---|----------------------|--|---------------------------|
| Aspect of inspection | Method of inspection | Frequency of inspection | Document retention period |
| Moulding sand characteristics | Lab. | Once a shift | 1 year |
| Ductile iron additives | Weigh/measure | Each treatment ladle | 1 year |
| Temp of melt in the casting ladle/furnace | Visual/pyrometer | Frequently | 1 year |
| Composition of metal/analysis | | | |
| — casting ladle | Lab. | Each treatment or each furnace or each ladle | 5 years |
| — continuous casting | Lab. | Once/3 tonnes | 5 years |
| Mould control | Visually | Regularly | — |
| Casting operation | Visually | Regularly | — |
| Standing time of each pouring ladle | Visually | Each cast | — |
| Mechanical properties | | | |
| — tensile strength | 6.2 | 6.2 | 5 years |
| — elongation % | 6.2 | 6.2 | 5 years |
| — nodularity | 6.2 | 6.2 | 5 years |
| — other materials | 6.2 | As per materials standard | 5 years |

Table A.3 — Final inspection and testing of products

| Clause no. | Aspect of inspection | Method of inspection | Frequency of inspection | Document retention period |
|------------|----------------------------------|----------------------|---|---------------------------|
| 7.1 | General | Visual | Every part | — |
| 7.2 | Vents ^a | Visual | Every cover | — |
| | Vents dimension ^b | Measure | 1 : 5 000 min. ^a | 5 years |
| 7.3 | Clear opening | Measure | 1 : 5 000 min. ^a | 5 years |
| 7.4 | Depth of insertion | Measure | 1 : 5 000 min. ^a | 5 years |
| 7.5 | Total clearance | Measure | 1 : 5 000 min. ^a | 5 years |
| 7.6 | Seatings | Measure | 1 : 5 000 min. ^a | 5 years |
| 7.6 | Cushioning inserts ^b | Measure | 1 : 5 000 min. ^a | 5 years |
| 7.7 | Edge protection | Measure | 1 : 5 000 min. ^a | 5 years |
| 7.8 | Securing | | | |
| | a) locking | Lab. | Type testing | 5 years |
| | b) mass | Weigh | 1 : 5 000 min. ^a | 5 years |
| | c) design feature | Measure | Type testing | 5 years |
| 7.9 | Slot dimension | Measure | 1 : 5 000 min. ^a | 5 years |
| 7.10 | Dirt bucket/pan ^b | Visual | 1 : 5 000 min. ^a | — |
| 7.11 | Positioning | Visual | Every unit | — |
| 7.12 | Surface condition | Measure | Type testing | 5 years |
| 7.13 | Loosening and removal | Lab. | Type testing | 5 years |
| 7.14 | Sealed manhole tops ^b | Lab. (seal mat) | Type testing | 5 years |
| 7.15 | Frame bearing area | Measure | Type testing | 5 years |
| 7.16 | Frame depth | Measure | 1 : 5 000 min. ^a | 5 years |
| 7.17 | Opening angle | Measure | 1 : 5 000 min. ^a | 5 years |
| 8.1 | Test load | 8.1 to 8.3 | 1 : 5 000 min. but at least once every 6 months | 5 years |
| 9 | Marking | Visual | Every part | — |

^a At least once every two months.
^b If applicable.

Table A.4 — Rolled steel

| Aspect of inspection | Method of inspection | Frequency of inspection | Document retention period |
|---|----------------------|------------------------------|---------------------------|
| Receiving inspection and testing of materials and consumables | Table A.1 | | |
| Process control | Table A.2 | | |
| Final inspection and testing of products | Table A.3 | | |
| — Welding of rolled steel ^b | | | |
| — Corrosion protection | 6.1 Measure | Once/hour or CS ^a | 1 year |
| Inspection, measuring and test equipment | Table A.6 | | |
| Handling, storage, packaging and delivery | Table A.6 | | |
| Control of nonconforming product | Table A.6 | | |

^a See Table A.1.
^b In the absence of a European Standard, the national standard(s) will apply. If the country of the user has no national standard for the welding of rolled steel, the national standard of the manufacturer's country will be applicable.

Table A.5 — Reinforced concrete (see 6.1 f)

| Aspect of inspection | Method of inspection | Frequency of inspection | Document retention period |
|--|--------------------------|-------------------------|--------------------------------|
| Receiving inspection and testing | | | |
| — rolled steel | ISO 630-1980 | — | — |
| — cast steel | ISO 3755-1976 | — | — |
| — steel bars for reinforced concrete | CS ^b | Every delivery | Certificate (ref: Euronorm 80) |
| — ready mix concrete | CS ^b | Every delivery | Certificate |
| — plant mix concrete | IQC ^c | IQC ^c | IQC ^c |
| Process control | Manufacturer's procedure | Regularly | 5 years |
| Compressive strength | | | |
| — ready mix concrete | 6.2 | Every delivery | 5 years |
| — plant mix concrete | 6.2 | IQC ^c | IQC ^c |
| Final inspection and testing of products | | | |
| — edge protection (7.7) | Table A.3 | Table A.3 | Table A.3 |
| — manhole tops of reinforced concrete | 8 | 1 : 5 000 ^a | 5 years |
| Inspection, measuring and test equipment | Table A.6 | Table A.6 | Table A.6 |
| Handling, storage, packaging and delivery | Table A.6 | Table A.6 | Table A.6 |
| Control of nonconforming product | Table A.6 | Table A.6 | Table A.6 |
| ^a At least once every two months. ^b See Table A.1. ^c See Table A.1. | | | |

Table A.6 — Inspection, measuring and test equipment Handling, storage, packaging and delivery Control of nonconforming product

| Aspect of inspection | Method of inspection | Frequency of inspection | Document retention period |
|--|--|-------------------------|---------------------------|
| Inspection, measuring and test equipment | | | |
| — Tensile load testing machine | Certificate ^a | Once a year | 5 years |
| — Compression load testing machine | Certificate ^a | Once a year | 5 years |
| — Other measuring equipment | Certificate ^b | Once every 6 months | 5 years |
| Handling, storage, packaging and delivery | Visually | Regularly | — |
| Control of nonconforming product | } According to manufacturer's approved documents | | |
| — Segregation | | — | 5 years |
| — Rejection | | | |
| — Reworking/retesting | | | |
| ^a This shall be done by an authorized institute. ^b Can be carried out by the manufacturer, using calibrated gauges. | | | |